

Figure 1

Removing the Element Assembly

(Please consult the Operation and Maintenance Manual for your specific product.)

- 1 Remove the element assembly from the filter housing by unscrewing the tee handle counter-clockwise.

Stripping the Element Assembly

- 2 Holding the tee handle, remove the compression nut and return tube washer and retain (**figure 1**).
- 3 Remove post seal.
- 4 Slide off all elements and post seals from return tube.

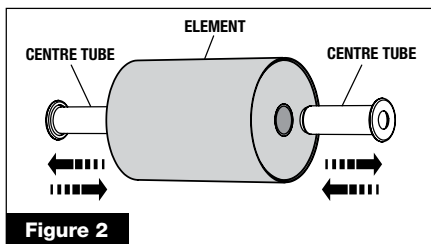

Figure 2

- 5 Remove the centre tubes from each end of the old elements and retain (**figure 2**).
- 6 Remove the top post seal and return tube washer, retaining the washer (**figure 3**).
- 7 Remove lid O-ring and lid gasket (**figure 3**).
- 8 Dispose of old elements, post seals, lid O-ring and lid gasket.

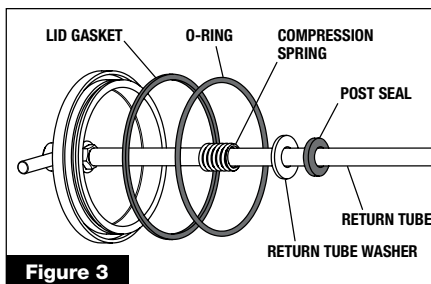

Figure 3

Reassembly of Filter Assembly

- 9 Carefully install the O-ring and lid gasket into lid (**figure 3**).
- 10 Slide the top return tube washer, then the post seal on to the return tube (**figure 3**).
- 11 Insert the centre tubes into the new elements. Ensure they are fully inserted (**figure 2**).
- 12 Load all the elements onto the return tube making sure there is a post seal between each element (**figure 4**).
- 13 Replace the bottom post seal, return tube washer and compression nut (**figure 5**).

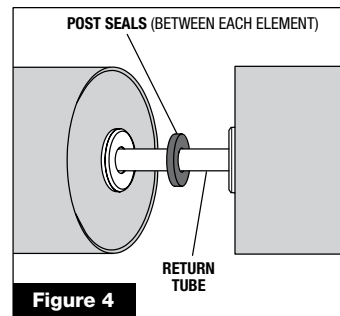

Figure 4

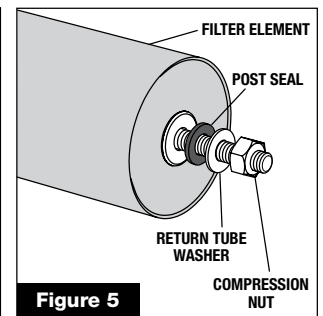

Figure 5

- 14 After loading all the elements and post seals on to the return tube, push down on the elements to seat them against the compression spring. This makes it easier to tension the compression nut correctly.

Tensioning the Compression Nut

- 15 Screw the compression nut firmly against the element assembly (**figure 6**), using the correct spanner (Part No FM 0027).
- 16 Continue tightening the compression nut until the correct length of thread is exposed. Check by using the notch on the handle of the spanner (**figure 7**).

Note: This is essential for the correct installation of the assembly into the housing, the subsequent sealing and the filter unit's performance.

Replacing the Element Assembly

(Please consult the Operation and

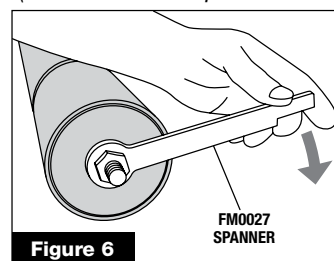

Figure 6

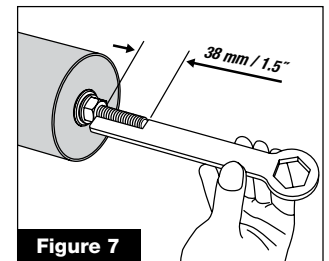

Figure 7

Maintenance Manual for your specific product.)

- 17 Insert the element assembly into the housing, carefully locating the lid O-ring into the housing tube.
- Note:** Take care not to dislodge the O-ring when assembling.
- 18 Tighten the tee handle until the lid gasket seats against the end of the housing, then tighten a further ½ turn (180°).
- 19 Crank engine and, where required, bleed any trapped air in filter housing via bleed screw fitted in tee handle (**figure 8**). Retighten bleed screw.
- 20 With engine running, check housing and lid for any fuel leaks. Rectify as required.

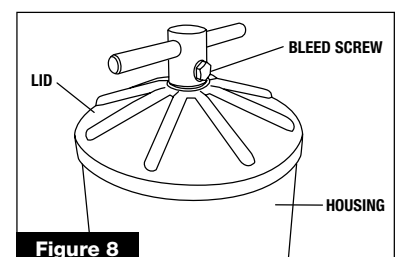
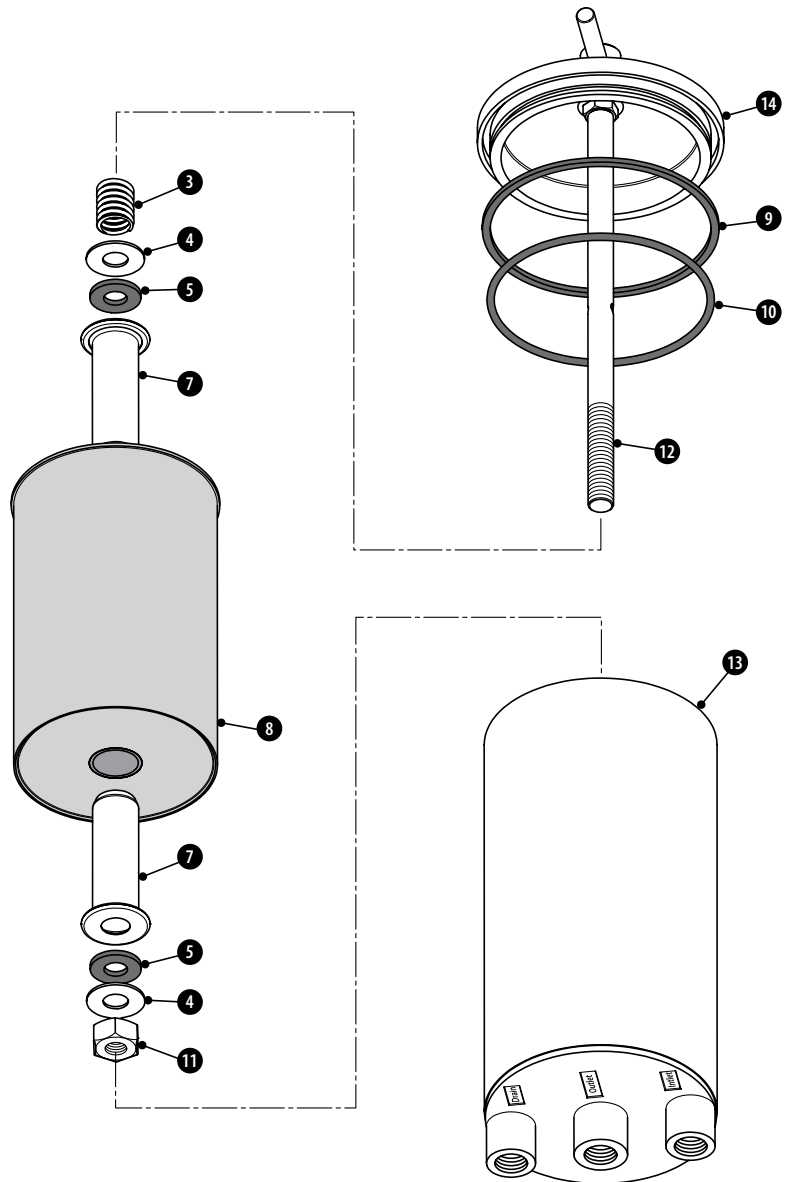
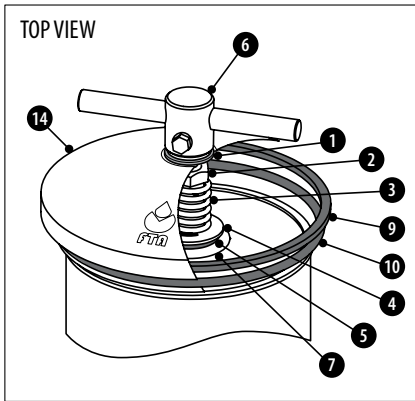

Figure 8

Note: FM3101 Filter Assembly shown



Item No	Qty	Description	Part No
1	1	Washer	FM0002
2	1	Lid lock nut	FM0005
3	1	Lid compression spring	FM0006
4	2	Return tube washer	FM0007
5	2	Post seal	FM0008
6	1	Tee handle with bleed screw	FM0010
7	2	Centre tube	FM0012
8	1	Element, fuel	FM2100
9	1	Gasket, lid	FM0004
10	1	O-Ring, lid	FM0025
11	1	Compression nut	FM0029
12	1	Return tube - No 1	FM0031
13	1	Housing - No 1	FM0051
14	1	Lid	FM0003

Element Replacement Parts List

Item No	Description	Part No	Quantity Required			
			FM3101	FM3102	FM3103	FM3104
5	Post seal	FM0008	2	3	4	5
8	Element	FM2100	1	2	3	4
9	Gasket, lid	FM0004	1	1	1	1
10	O-Ring, lid	FM0025	1	1	1	1

Note - Industrial oil, fuel and engine oil filters
ALL seals to be replaced EVERY element change.

Required Tools

